

Southern
Regional
Aquaculture
Center



December 1994

Selecting the Proper Pump

J. David Bankston, Jr., and Fred Eugene Baker*

Before you can select a pump that will fit your needs, you must know four things: 1) the total head or pressure against which it must operate, 2) the desired flow rate, 3) the suction lift, and 4) characteristics of the fluid. Aquaculture operations imply that you will be pumping water, but you also need to know such things as the temperature range, the corrosiveness (is it salty water?), and how much and what kind of trash or debris such as sand, dirt, leaves, fish or twigs may be in the water. With this knowledge, you and your dealer can select the proper pump.

The total head, suction lift and flow rate are dependent upon the piping system and the pump's characteristics. The piping system and the pump interact to determine the operating point of the pump - flow rate and pressure. The pump cannot independently control these parameters. As the flow rate is increased the work to move each unit of water or total dynamic head the pump must produce increases as shown in curve A in Figure 1. A pump will typically have reduced capacity as the pressure or head it is pumping

against increases. This is sketched as curve B. The operating point of the system occurs when the two curves cross.

In order to obtain a pumping system that will meet your requirements, and meet them in an efficient manner, you must match the pump to the piping system and required flow rate. Manufacturers should be able to supply a pump curve which shows the performance of the pump and the allowable operating ranges. Do not plan to operate outside of this recommended range outside this may damage the pump. Your dealer may also be able to help you analyze or plan your piping system. Information on piping systems is also available in the SRAC Publication No. 373, *Piping Systems*.

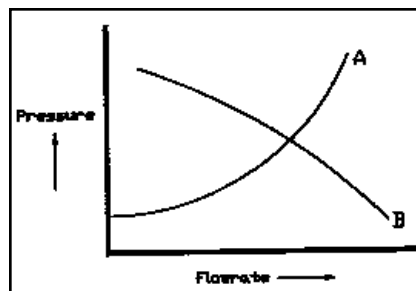

Figure 1. Pressure as a function of flow rate for a typical piping system (A) and a typical centrifugal pump (B).

A cost analysis of pumping will consider initial cost of capital investment, annual fixed cost and operating cost. All three costs are somewhat dependent on each other. The type of pumping equipment, size of pipelines, size of pumps and type of water supply affect not only the initial cost but also the fixed cost as well as the operating cost. For example, piping systems using large pipes may cost more but could allow the use of smaller horsepower pumps which cost less, require smaller power sources and cost less to operate than a piping system with small diameter pipe.

The lowest priced system is not always the best buy, especially if the lower price means less efficient pumps. To get the most efficient pump, an analysis should be made of all pumping requirements. Key points to consider are:

- net positive suction head (NPSH)
- priming
- flexibility
- corrosion
- useful life
- maintenance
- quantity pumped
- pumping head
- power source
- economics.

*Louisiana Cooperative Extension Service, Louisiana State University Agricultural Center.

The NPSH is the amount of energy in the water at the pump's inlet. The required NPSH is a characteristic of the pump and depends on pump design, size and operating conditions. The required NPSH is determined by the pump manufacturer. The available NPSH must equal or exceed the required NPSH. The available NPSH is a characteristic of the piping system. For the system shown in Figure 2, the NPSH may be calculated as:

$$\frac{(\text{atmospheric pressure} - \text{vapor pressure})}{2.3} - h - \text{friction loss in pipe}$$

The vapor pressure in this equation is dependent upon water temperature and both it and the atmospheric pressure are expressed in pounds per square inch while h and friction loss are expressed in feet.

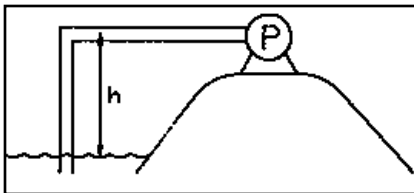

Figure 2. Simple pump system.

Types of pumps

Pumps used in irrigation or aquaculture often are a form of the centrifugal pump. Two basic types of centrifugal pumps are horizontal and vertical. As the name implies, centrifugal pumps use centrifugal force to move water from one point to another and to overcome resistance to its flow. In its simplest form, this pump consists of an impeller fixed on a rotating shaft within a volute-type (spiral) casing. Water enters at the center of the impeller and is forced to the outer edge at a high velocity by the rotating impeller. The water is discharged by centrifugal force into the casing where the high velocity head is converted to pressure head.

The axial flow propeller pump is another type that is used. It is often used in low-lift, high-volume situations. The propeller

may look like an impeller, but the force imparted to the water is parallel to the propeller shaft.

Operating principles

To operate properly, a centrifugal pump must be submerged in a source of water or be filled with water and connected through a water-filled, airtight pipe to the water source. In the latter case, water is pushed into the pump by the difference between atmospheric pressure and the pressure at the pump entrance. (The efficiency and capacity of the pump is extremely sensitive to any leak in the inlet piping.) After the pump is started, the impeller throws the water outward by centrifugal force and creates an area of low pressure at its center. This pressure is lower than atmospheric pressure and is commonly called a vacuum. Since atmospheric pressure is pushing down on the surface of the source of supply, the water is forced through the suction pipe to the lower pressure area at the center of the impeller to replace the water being thrown outward. Thus, there is a continuous flow of water through the pump.

Theoretically, if a pump could be designed to produce a perfect vacuum at its center and was being operated at sea level, the atmospheric pressure of 14.7 pounds per square inch acting downward on the surface of the water source would be capable of forcing water up the suction line to the pump a vertical distance of 34 feet. In practice, this is impossible, because a perfect vacuum cannot be created at the center of the impeller and because there are losses caused by friction created by the flow through the suction line. There are also losses caused by turbulence at the entrance to the suction line and at the entrance to the impeller. Usually, a vertical suction lift of about 15 feet is considered the maximum for reasonably efficient operation.

Operating a pump under a lift larger than it was designed for may cause cavitation. Cavitation is the formation of vapor (steam) bubbles when the pressure drops below the vapor pressure of the water. This results in inefficient operation and will usually damage the pump. A pump that is cavitating may have a rattling sound.

Horizontal centrifugal pumps

(for surface supply and shallow wells)

Horizontal centrifugal pumps are frequently used if the source of water is a surface supply, such as a lake, stream, canal or pond, or a shallow well. A shallow well, as opposed to a deep well, is one in which the water level in the well is high enough to permit the vacuum at the pump to lift the water and keep it flowing at an acceptable rate. As the name implies, horizontal centrifugal pumps normally have a horizontal shaft. This type of pump is usually subdivided into two groups, single suction (end suction) and double suction (often called split case). Either of these may be single or multistage; that is, they may have only one impeller or they may have two or more impellers. These impellers are so constructed that the water, in passing through the pump, is conducted from the discharge of one impeller to the suction of the second; thus, the total head is that developed by a single impeller multiplied by the number of impellers in the pump.

The most common pump and the lowest in cost is the end suction, single stage (Figure 3). Available sizes vary with the manufacturers.

Jet pumps

A jet pump is often used for very low capacity requirements (5 to 20 gpm), such as a home water system. This pump consists of a small centrifugal pump located at ground level connected to a jet installed below the water level in the well (Figure 4). By circulating

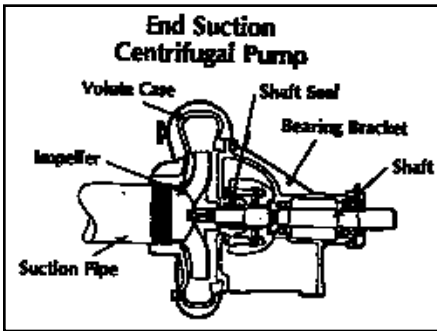

Figure 3. Diagram showing construction of the most commonly used pump and the lowest in cost.

part of the water from the pump back through the jet, water is forced up to the impeller in the pump, and a continuous flow at reasonable pressure is provided.

Shallow-well jet pumps operate on the recirculation principle, but the jet is installed above ground and the allowable lift is limited to about 22 feet. Deep-well jet pumps, however, have a maximum lift of about 65 feet.

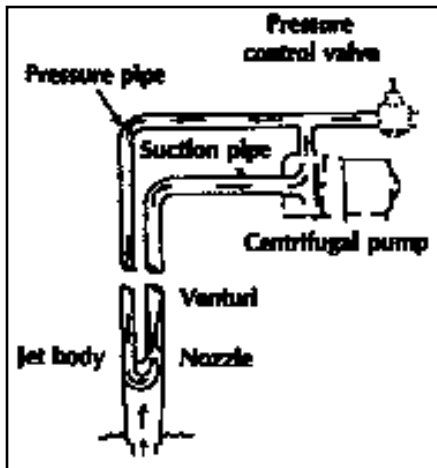

Figure 4. Parts of a jet pump. This pump is used most often for low capacity requirements, such as a home water system.

Jet pumps are designed for home water systems, and their capacities are seldom adequate for aquacultural purposes. Also, the jet pump requires about twice the horsepower that a submersible requires to deliver the same amount of water from the same depth.

Axial flow propeller pumps

Axial flow propeller pumps are designed to operate efficiently for aquacultural, irrigation or drainage pumping at low head and high volume (more than 500 gpm). Their efficiency is high, especially when the total head is in the range of 8 to 20 feet. The pumping element of an axial flow propeller pump consists mainly of a revolving propeller in a stationary bowl which contains vanes above and below the propeller. Water enters the pump through the intake bell. It is discharged into the distributor section and then out the discharge elbow. Flowing in essentially a straight line along the pump axis keeps friction and turbulence to a minimum. The propeller of an axial flow pump must be submerged in the source of water (Figure 5). One of the advantages of this pump is that it will handle some debris.

Deep well vertical turbine pumps

For a deep well, the most widely used pump is a vertical centrifugal, commonly referred to as a "deep well turbine." Basically, this is a centrifugal pump designed to be installed in a well. It will not handle debris. It consists of four major components:

- 1) **Bowl assembly** - this contains one or more impellers, each in its own housing.
- 2) **Column and shaft assembly** - this consists of the pipe to suspend the bowl assembly in the well and carry the water to the surface. Inside this pipe (or column) is the shaft that connects the impeller shaft to the driver located at ground level. The shaft may be either water lubricated or oil lubricated.
- 3) **Discharge assembly** - this often is called the "head or base." It is normally cast of iron and designed for installation on a foundation. It supports the column and shaft assembly and the bowl assem-

bly in the well, provides a discharge for water being delivered, and also accommodates the driver for the pump.

- 4) **Driver** - this may be either an electric motor or a right-angle gear for connection to a power unit. When an electric motor is used, the usual type is a vertical hollow-shaft design that permits the pump shaft to come up through its center for securing at the top. The right-angle gear also is usually the hollow-shaft design type for the same reason and has a horizontal shaft for connection to the engine drive or power take-off. The internal gears are available in various ratios to accommodate any engine with an operating speed different

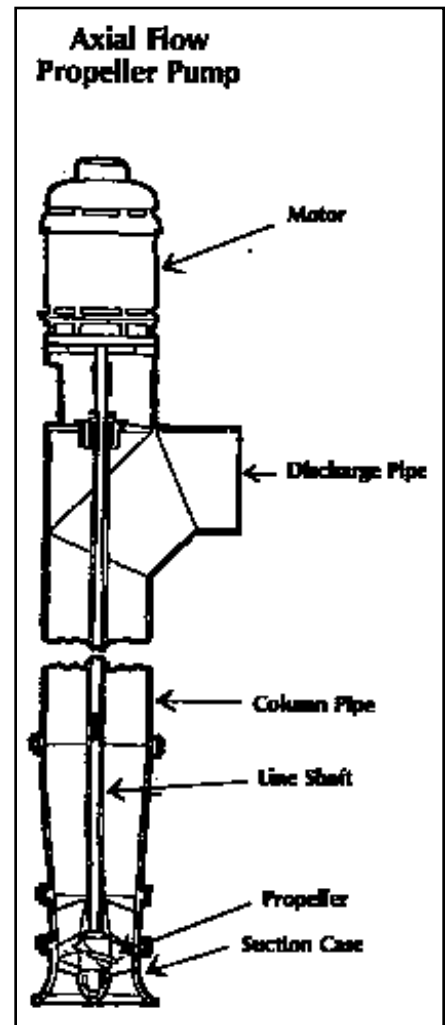

Figure 5. Diagram showing parts of an axial flow propeller pump.

from the desired pump-operating speed.

Because of the limited diameter of its impellers, each impeller develops a rather low head, and it is necessary in the average application to stack several impellers in series one above the other with each in its own bowl or diffuser housing. This is called staging. Thus, a four-stage bowl assembly contains four impellers, all attached to a common shaft through the separate housing or bowls. The bowl shaft is attached to the line shaft through the center of the pump column pipe and must be long enough to locate the bowl assembly below the level of the water in the well when pumping at required capacity.

For any given capacity and speed, each impeller develops a certain amount of head. For example, assume that a well has a 10-inch casing and a static water level 60 feet below the surface and that a pump is needed to deliver 1,500 gpm. In this example the static water level is 60 feet below the surface. When water is being pumped from the well, the water level will fall. This distance the level falls when pumping is called **drawdown**. Drawdown varies with localities, the formation into which the well is drilled and the amount of water pumped. Assuming in this case the drawdown is 40 feet (at a pumping rate of 1,500 gpm), then the total distance to the surface becomes 100 feet. In addition we have pipe friction and inlets and outlets which add 21 feet of head. Therefore, the total head the pump must develop is 100 feet plus 21 feet, or 121 feet. If an impeller were available that delivered 1,500 gpm at a head of 22 feet, a 6-stage pump would be required.

Optional vertical turbine pump features

You can get most pumps with construction features to suit individual preferences and particular applications.

Water-lubricated

Water-lubricated pump column assembly is provided with fluted rubber bearings to permit the water being pumped to lubricate the shaft. If the pump is to be operated at less than about 2,200 rpm, these bearings, which are fixed in the column pipe coupling, are usually placed at 10-foot intervals. For higher speeds, the bearings are on 5-foot spacings.

Water-lubricated turbine pumps are simpler, cheaper and more commonly used. If more than four or five of the rubber shaft bearings are above the water level and become dry when the pump is not operating, some means of pre-lubrication, such as a small pre-lub tank from which water can be spilled over the bearings before starting the pump (Figure 6), is required. With smaller pumps, a foot valve can be installed below the bowl assembly to keep the column pipe full of water. Because of friction loss, it is impractical to use a foot valve for applications requiring large flows.

When the water level is very deep, oil lubrication is normally used. Although there is no definite point at which it becomes necessary, it is usually recommended for depths of more than 150 to 200 feet.

Oil-lubricated pump column assembly includes a tube which encloses the shaft. Inside

includes a tube which encloses the shaft. Inside the tube are bronze shaft bearings threaded on the outside to serve as couplings. Alternatively the tube may have oil-impregnated redwood bearings. Lubricating oil is fed into the top of the tubing and passes by gravity over surfaces of the bearings. At the bottom of the column is an opening that lets oil flow out (Figure 7).

To maintain the pump, drain and clean the oil reservoir each year and then fill the reservoir with the proper turbine oil specified by the individual pump supplier. Take care that the oil reservoir contains enough liquid to lubricate the

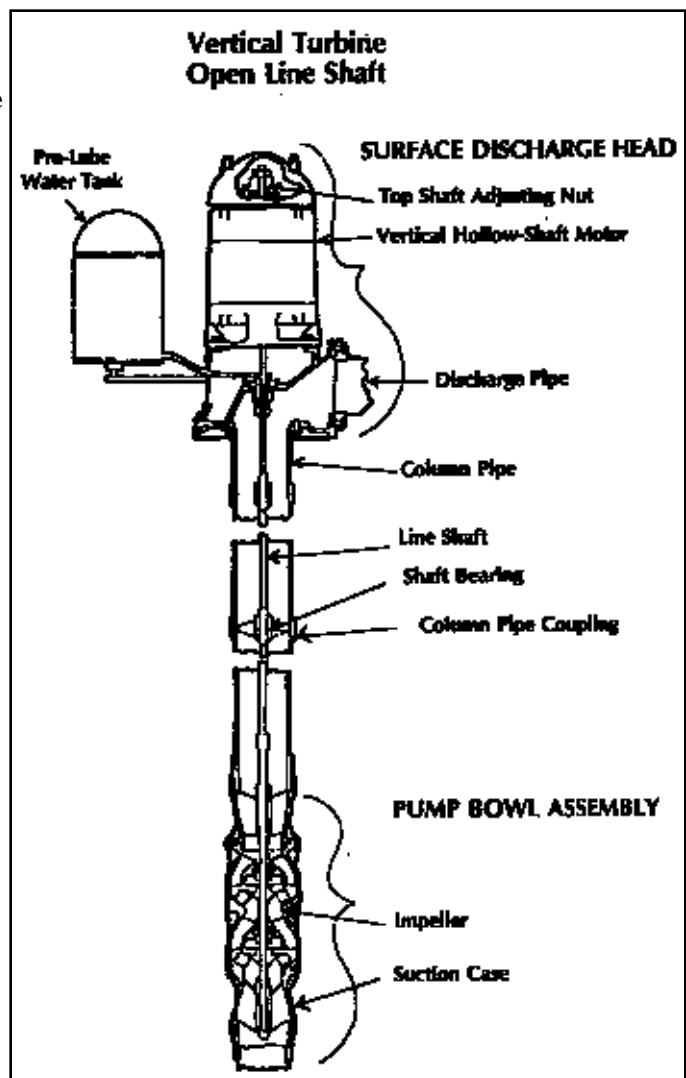

Figure 6. This diagram of a water-lubricated pump column assembly shows the parts of the surface discharge head and the pump bowl assembly.

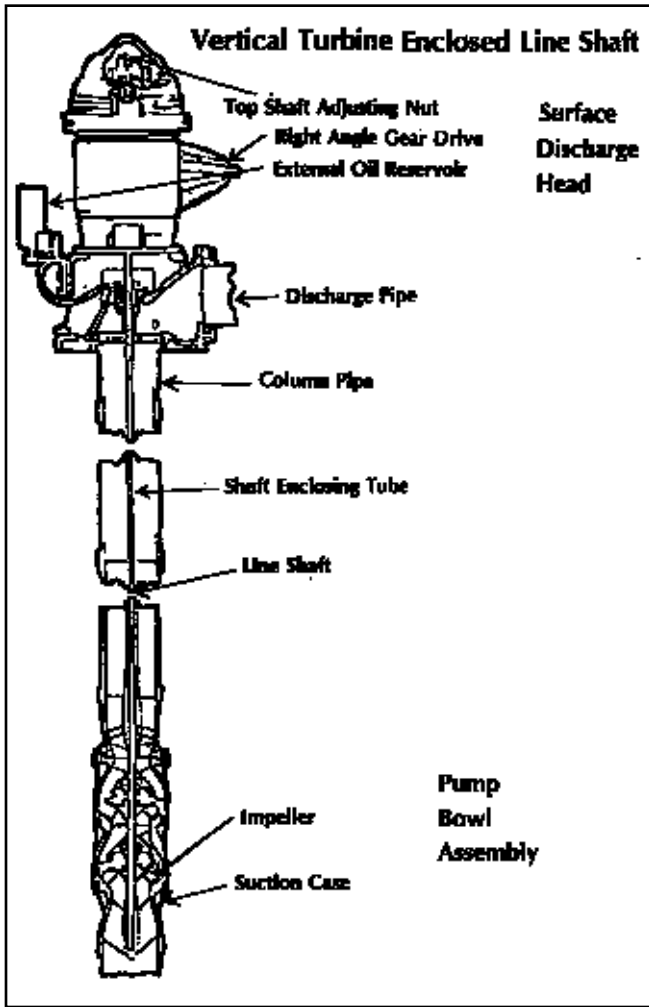

Figure 7. An oil lubricated pump column assembly showing parts of the surface discharge head and the pump bowl assembly.

pump at all times. A drip adjustment controlling the amount of oil allowed to flow into the pump should comply with the manufacturer's specifications. Do not over-lubricate the pump or leave the oil flowing when the pump is not operating. Too much lubrication flowing into the oil tube will cause additional friction loss that could cause the tube to plug and bearings to wear.

Submersible pumps

The submersible pump consists of a multistage vertical turbine pump connected directly to an electric motor designed to operate under water. Both the pump and motor are suspended in the well below the water level by a pipe that conducts the water to the sur-

face (Figure 8). This type is available in a wide range of capacities for 4-inch wells and larger.

Most submersible pumps used for aquaculture require three-phase electrical service.

Enclosed vs. semi-open impellers

In an enclosed impeller, vanes are covered on both top and bottom edges; in a semi-open impeller, only the top edge of the vanes is covered. Figure 9 shows top and bottom views of the impellers. The bottom edge of the vanes runs with close clearance with the pump bowl. By raising the setting of the semi-open impellers, the clearance between

the vanes and the bowl seat is increased, and water is allowed to circulate through this area. This makes possible a variation in how the pump performs at any given speed. Thus, by adjustment of the impeller clearance, a specific performance can be maintained even though there is a change in the water level. With enclosed impellers, performance and efficiency are not affected by small differences in their position, and constant performance can be maintained.

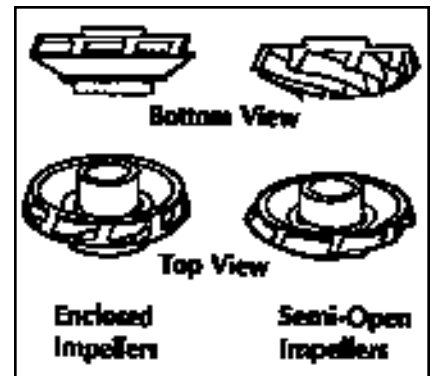

Figure 9. Views of impellers.

Choice of impellers

The impeller of the pump has a wear ring that must match with a similar wearing surface in the bowl of the pump. It is necessary to maintain the proper clearance between these two surfaces and to allow for the stretch of the drive shaft within the pump. Periodic adjustment of the impeller clearance is essential for high efficiency operation. Contact your pump installer at least once every five years to make the adjustments. Pumpers who periodically adjust the thrust nut to get impeller clearance should take care to make the proper adjustment.

Nonreverse ratchet

At a small additional cost, either an electric motor or a right-angle gear drive can be provided with a ratchet to prevent the pump's rotating in reverse. Some electric motors will operate in either direction. If it should be operated in the wrong direction because of phase reversal in the power sup-

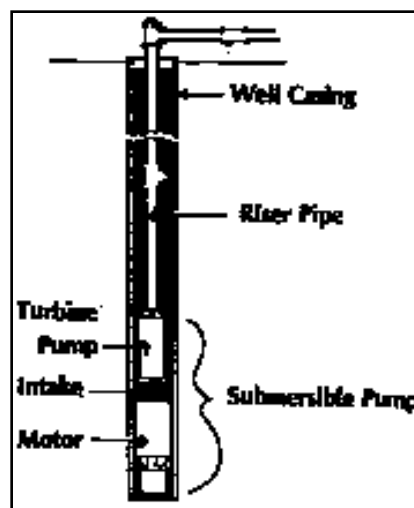

Figure 8. Parts of a submersible pump below ground connected by a pipe to the surface.

ply, the pump may be damaged. Reverse spin can also occur after stopping because the water flowing back down the pump column through the impellers turns them like a water wheel. Undue wear is caused by the shaft's being turned in its bearings without water for lubrication.

Basic considerations

If you must lift water, reducing the lift will improve the overall efficiency of operation. Surface sources of water usually require much less lift than pumping from wells. Two common types of pumps designed primarily for low-lift operations are the propeller axial flow pump and the horizontal PTO-driven centrifugal pump. Axial flow propeller pumps have very high efficiencies and are capable of pumping large volumes. Horizontal centrifugal PTO-driven pumps are less efficient but still maintain the capability of pumping large volumes of water. They also are portable and often fit into a flexible management plan for aquaculture production.

Pump efficiency

All segments of our economy, including aquaculture and agriculture, must make the most efficient use of available energy sources. Selecting a correct pumping plant not only will conserve valuable energy supplies but also will reduce total annual pumping costs. Inefficient pumping plants can increase costs dramatically.

Meaning of efficiency

The efficiency of a pump is a measure of the degree of its hydraulic and mechanical perfection. Pump efficiency is the ratio of the output water horsepower to the input shaft horsepower expressed as a percentage:

$\text{Pump Efficiency} = \frac{\text{GPM} \times \text{Total Head} \times 100}{\text{Input HP} \times 3,960}$
--

A horsepower is defined as the power required to raise a weight of 33,000 pounds a vertical distance of 1 foot in 1 minute. The rate of work performed by a pump (in horsepower) is proportional to the weight of the water it delivers per minute multiplied by the total equivalent vertical distance in feet through which it is moved. For example, a pump delivering 396 gallons per minute at a total head of 10 feet is performing work at the rate of 1 horsepower. If it were possible to achieve 100 percent efficiency, it would only be necessary, in this instance, to apply 1 horsepower to the pump shaft. In practice the energy input must be greater than 1 horsepower.

Some of the energy losses that result in lower efficiency are friction in the bearings that support the pump shaft, friction between the shaft and the packing in the stuffing box, unavoidable leakage between areas of high pressure and adjacent areas of low pressure inside the pump case, and the friction caused by the water moving across the metallic surfaces in the pump. There are also other losses of a more complex nature.

Determining pump efficiency

The efficiency of a pump is determined by actual tests. Referring to the example just mentioned: If 1.25 horsepower must be applied to the input shaft when the pump is doing work equivalent to 1 horsepower, the pump efficiency will be 80 percent (1 divided by 1.25).

During a test, the total head that a centrifugal pump can develop is a function of the speed at which the impeller is turned and the diameter of the impeller. If a pump impeller is being turned at its rated speed and a valve on the discharge side of the pump is closed, it will develop a certain maximum head. Under these conditions, this head is read on a

pressure gauge. The gauge reading translated into feet registers the height to which the pump is capable of elevating water. This is known as the "shut off head."

If the valve is slowly opened, the pressure gauge reading will fall as the flow increases, and this will continue until some point of maximum flow and minimum head is reached. If the total head being developed at any given rate of flow is plotted against the quantity of water being delivered, the result will be a performance curve for this particular pump at this particular speed. If you observe the power required to turn the pump during this process, you will note that the power is at a minimum for this typical centrifugal pump when there is no water being discharged from the pump and that the power required will gradually increase as the rate of flow increases and the head decreases. The maximum efficiency will be about midway between zero flow and maximum flow. A typical turbine pump performance curve is shown in Figure 10, a typical axial flow propeller pump curve in Figure 11.

A pump designer often must sacrifice some degree of efficiency to achieve some other desirable characteristics to provide a unit with maximum usefulness. Available pump efficiencies vary with the pump size, type, etc., but usually should be between 65 percent and 85 percent. However, this does not mean that a pump used in an aquaculture application is either capable of or operates at that range of efficiency. For example many pumps used in crawfish production in Louisiana had efficiencies of less than 30 percent. If you do not have a pump curve for the pump or haven't determined its operating point, you are just guessing or gambling on its performance. Where practical, select a pump which will operate near the point of its curve where maximum efficiency is reached. This is referred to as the "design point."

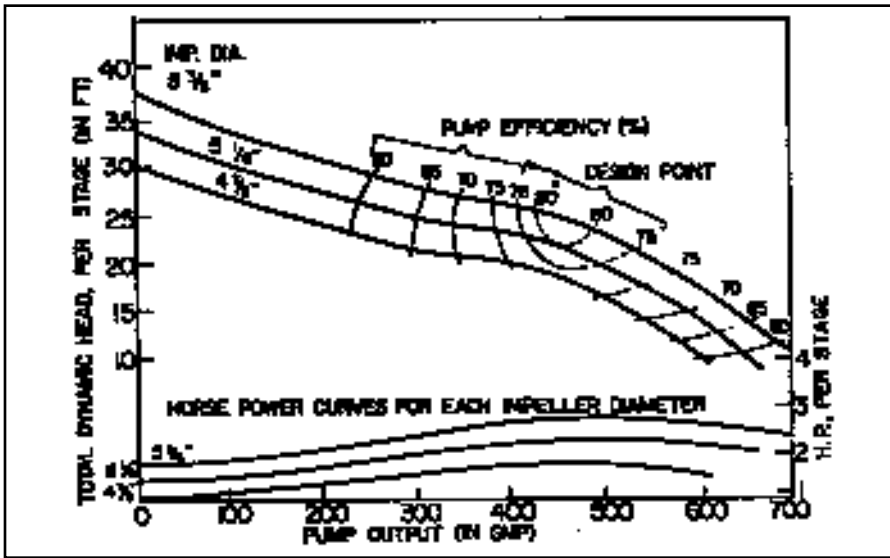

Figure 10. A typical performance curve of an 8-inch turbine pump 1,760 rpm.

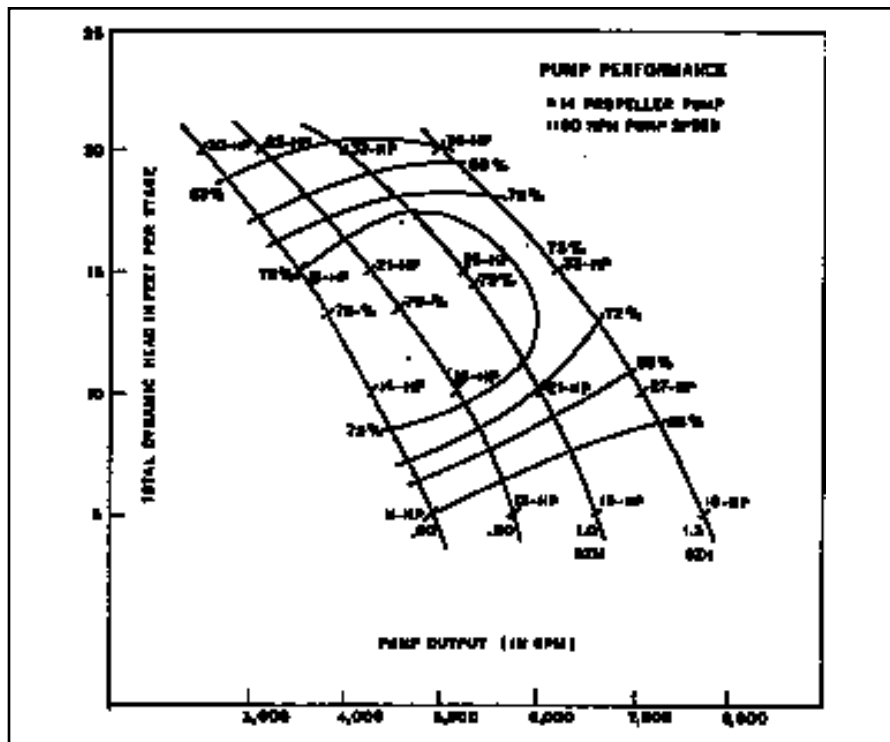

Figure 11. A typical axial flow propeller pump curve.

Remember, the point at which the pump operates depends upon the pump and upon the piping arrangement. The pump's operating range and environment should also conform to the manufacturer's recommendation to prevent damage.

Pumping from a well

Changes in pumping heads because of different operating systems usually require a change in the pumps to maintain greatest efficiency.

Does your pump surge? If you observe a surge in the discharge, the pump may be having difficulty getting enough water. Assum-

ing that adequate water is available to flow into the well and that encrusted wells are not the problem, then the surge is normally caused by the pump not being submerged enough to provide water for intake. Where the pump is located some distance from the bottom of the well, it is often possible to lower the pump and reduce the amount of surging. This can require more power since full water flow may be obtained along with higher head. This may overload the existing motor. Ask your pump installer to evaluate the capability of the existing pump to provide the required water. In some instances you may have to add another stage and change the motor to one of greater horsepower.

When the pump is set near the bottom of the well and it is impossible to lower the pump to minimize surging, consider other alternatives. Long-term solutions resulting in higher efficiency include pulling the pump and trimming the impeller or replacing the pump with a different pump of a smaller capacity. It might also be possible to decrease the pump speed and thus decrease the amount of water which is pumped, but this could result in a sizable decrease in efficiency.

These short-term solutions for a single pumping season will result in a decrease in efficiency; adjustment of the impellers upward, throttling of the discharge by closing a valve on the discharge side, and, for belt-driven pumps, the exchange of pulleys in such a way to decrease rpm.

Consult your individual pump installer for the best solution to your problem, realizing that year-by-year fluctuations in the water table may cause the problems.

Does your well pump sand? If you observe sand in the discharge after the initial period of development, remember that this sand is wearing the pump and that continuous maintenance and replacement will be necessary to provide

the desired capacity and overall efficiency. Sand in the water wears the impeller and the bearings, and the pump must be pulled periodically and worn parts replaced. Sand is usually caused by poor well design and/or poor well screen selection. If you cannot correct the problem you will need to be particularly concerned about loss of efficiency and capacity. If your well is pumping sand, monitor its performance or ask your pump supplier to determine the overall efficiency. If you can measure the appropriate quantities (flow rate, total head and input horsepower) you can determine efficiency from the equation for pump efficiency. Even without measurement you may be able to determine from the pump's performance that it is operating inefficiently. If efficiency is low, pull the pump and make the needed repairs. You may also consider whether a different type of pump could handle the sand.

Well size and capacity limits

There are definite capacity limitations for a given diameter of well casing. To obtain this limit, the pump must have sufficient capacity. The capacity of a centrifugal pump varies directly with its speed of operation. It may be necessary to increase the pump speed

to get maximum capacity from a given well size. Maximum permissible speed depends upon a number of factors, but for 4-inch, 6-inch and even 8-inch pumps, a speed of 3,600 rpm is not uncommon. For larger sizes, however, this speed is not advisable. Since nominal electric motor speeds used in pumping are either 1,760 rpm or 3,450 rpm, intermediate speeds may be achieved with right-angle gears of suitable ratio or with belt and pulley drives.

The following are considered normal maximum capacities expected from deep wells:

SIZE	UP TO
4 - inch	90 gpm
6 - inch	400 gpm
8 - inch	600 gpm
10 - inch	1,000 gpm
12 - inch	2,000 gpm

These figures are not limiting. Much depends on the water level, yield characteristics of water-bearing formation and the pressure to be developed, but they serve as a general guideline. In any case, evaluate carefully the overall installation. For instance, although 1,000 gpm may be obtained from a 10-inch pump with reasonably good efficiency, a 12-inch pump may be better considering overall cost.

Pumping plant efficiency

A pumping plant is a combination of a pump and power unit. Overall efficiency is a product of both the pump's and the power unit's efficiency. Table 1 lists obtainable efficiencies of the components of a pumping plant.

For electric motors, the efficiency ranges from about 85 percent to 92 percent. Typical thermal efficiency of an internal combustion engine ranges from 5 percent to 37 percent. Typical efficiency of an individual pump will vary between 25 and 85 percent. Thus the greatest theoretical efficiency for a good pumping plant seldom exceeds 70 percent.

Tests conducted in the field indicate that pump efficiencies could vary from less than 10 percent to about 75 percent, but average 50 percent to 60 percent. Pumps operating at an efficiency of 60 to 70 percent seldom need major adjustments or major repairs, but they can be improved, usually by adjusting the impeller and following recommendations for adjustments and maintenance. Pumps with an overall efficiency of less than 50 percent usually require major repairs and should have immediate attention to reduce pumping costs.

Type	Attainable Efficiency Percent	Useful Life* (Yrs)
Centrifugal-type pump	75-85	15
Right-angle pump drive (gear head)	95	15
Automotive engines		
- gasoline	20-26	9
- LPG	20-26	14
Light industrial engine (diesel)	25-37	14
Electric motors	85-92	25

*Based on 2,000 hours per year of use. With proper maintenance and fewer hours of annual use, the useful life could be increased.

The work reported in this publication was supported in part by the Southern Regional Aquaculture Center through Grant No. 89-38500-4516 from the United States Department of Agriculture.